

SYLO104D6J1

Unit Parameters

Model	SYLO104D6J1
Rated Power (kW/kVA)	104/130
Speed (rpm)	1800
Frequency (Hz)	60
Rated Voltage (V)	440
Phase	3
Speed Control Type	Electronic speed control

Unit Size and Weight

Length (mm)	3440
Width (mm)	1140
Height (mm)	2000
Net Weight (kg)	2250

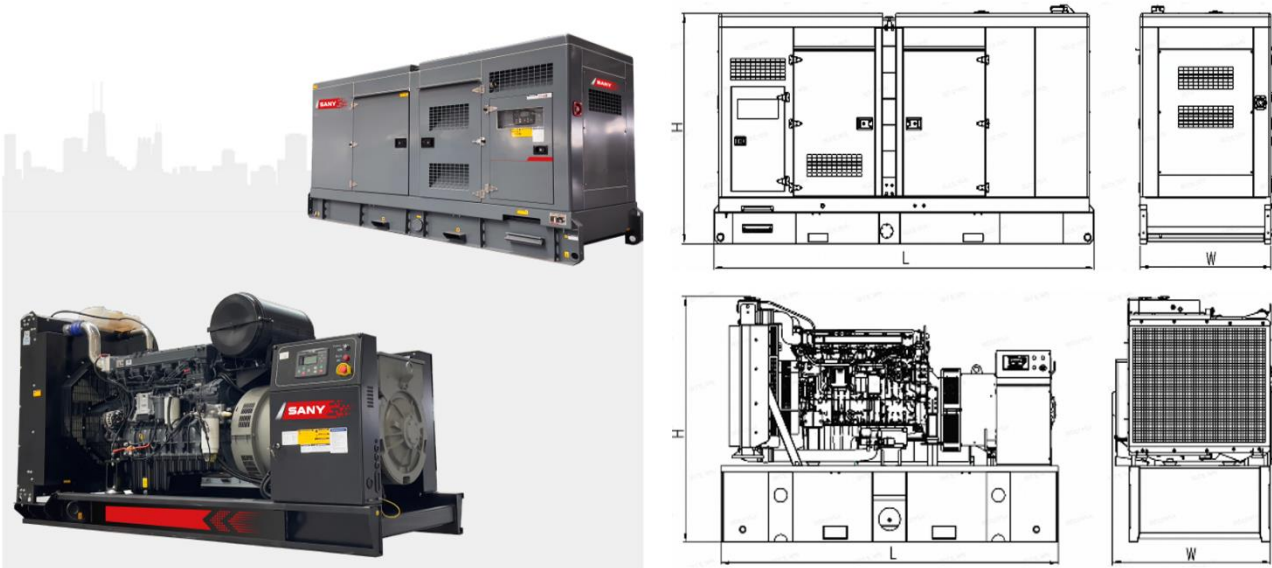

* The above is for reference only, the actual size and weight are subject to the final design drawings.

SYLO104D6J1

Engine

Brand	HUNAN DEUTZ	
Model	BF4M1013FC	
No. of Cylinders	4	
Displacement (L)	4.76	
Bore × Stroke (mm)	108×130	
Starter Voltage (V)	24	
Fuel Consumption (L/h)	100% load	31.9
	75% load	23.0
	50% load	15.4
	25% load	8.5

Alternator

Brand	Leroy Somer	
Model	TAL A44E	
Mode of connection	Three phases and four lines	
Connection type	Y-shaped connection	
Exciter system	SHUNT	
Voltage regulator	R120	
Bracket type	Single bearing	

Controller

Brand	DEIF	
Model	SGC420MKII	

Generator



SYLO104D6J1



Configurations

“ <input checked="" type="checkbox"/> ” configuration items	“ <input type="checkbox"/> ” No configuration items	
Standard configuration	Optional configuration	
<input checked="" type="checkbox"/> Engine	<input checked="" type="checkbox"/> Fuel-water separator	<input type="checkbox"/> Pre-lubrication system
	<input type="checkbox"/> Water jacket heater	<input type="checkbox"/> Inlet air shutdown valve
	<input type="checkbox"/> Engine oil heater	<input type="checkbox"/> Gas start system
	<input type="checkbox"/> Heavy-duty air cleaner	
<input checked="" type="checkbox"/> Alternator	<input type="checkbox"/> Permanent magnet generator	<input type="checkbox"/> Stator temperature sensor
	<input type="checkbox"/> Digital voltage regulator	<input type="checkbox"/> Bearing temperature sensor
	<input type="checkbox"/> Anti-condensation heater	<input type="checkbox"/> Differential protection
<input checked="" type="checkbox"/> Single-machine control	<input type="checkbox"/> Parallel control	<input type="checkbox"/> Redundancy control
	<input type="checkbox"/> Grid-connected control	<input type="checkbox"/> Remote monitoring system
<input type="checkbox"/> 40°C Radiator	<input checked="" type="checkbox"/> 50°C Radiator	
<input checked="" type="checkbox"/> Unit integrated output	<input type="checkbox"/> Individual output cabinet	
<input checked="" type="checkbox"/> Battery negative switch	<input type="checkbox"/> Battery charger	
<input checked="" type="checkbox"/> Maintenance-free lead-acid battery and cable		
<input checked="" type="checkbox"/> Industrial muffler	<input type="checkbox"/> Residential muffler	<input type="checkbox"/> Fire extinguishing muffler
<input type="checkbox"/> No fuel tank	<input checked="" type="checkbox"/> Chassis tank	<input type="checkbox"/> Daily-use fuel tank
<input checked="" type="checkbox"/> Rubber damper	<input type="checkbox"/> Spring bumper	
<input checked="" type="checkbox"/> Steel chassis	<input checked="" type="checkbox"/> Silent box type noise reduction box	<input type="checkbox"/> Container type noise reduction box
	<input type="checkbox"/> Tool kit	

*Special instructions:

The Rated power is the maximum power that a unit can operate continuously with variable load under standard environmental conditions, and is allowed to operate at an overload of 10% for 1 hour every 12 hours.

*Operating conditions and power correction:

Altitude: $\leq 1000\text{m}$ (power correction required when $>1000\text{m}$).

Environmental temperature: $40\text{ }^{\circ}\text{C}$ (power correction required when $>40\text{ }^{\circ}\text{C}$).

Relative humidity: $\leq 60\%$.

Land use.

Fixed on the ground during power supply to prevent movement.

When the operating conditions of the generator set do not meet the above conditions, the generator set needs to meet user needs through optional configurations, and the rated power value of the generator set needs to be corrected under high altitude and high temperature conditions.